

Model Shown:
9030A, 9008A, 9112A



Features

IDEAL FOR INDUSTRIAL LIFTING AND PUSHING APPLICATIONS FOR MRO

- Choose from this complete line of premium quality bottle jacks. Ideal for use in any number of industrial lifting and pushing applications.
- The 9110B, 9015B, 9022B and 9033B feature a beveled base which allows the jack to “follow” the load, reducing the chance of dangerous side-loading.
- Jacks feature a screw extension for quicker setup.
- High strength piston and pump linkage for long life.
- All models include over-travel protection.
- Lever Bar included on all models. All jacks can be used in the vertical, angled or horizontal positions.
- Serrated or contoured saddles help stabilize the load for a safer lift.
- 110 ton jack features dual pumps for time-saving two-speed operation.
- All jacks meet ASME B30.1 standards and carry the Power Team PowerThon™ Lifetime Warranty.

Ordering Information

Order Number	Cap. (tons)	Stroke (mm)	Retracted Height Min. (mm)	Length of Screw Ext. (mm)	Height with Screw Ext. (mm)	No. Pump Strokes to Ext. Piston	Saddle Dia. (mm)	Base Size (mm)	Pump Handle Length (mm)	Handle Effort at Rated Cap. (kg)	Carry Handle	Metric Tons @ 700 bar	Prod. Wt. (kg)
9002A	2	114	181	49	344	5	25	110x65	311	34,0	No	1,8	2,2
9003A	3	114	191	60	365	10	29	114x72	489	20,4	No	2,7	2,6
9005A	5	121	200	70	391	12	35	132x76	545	24,9	No	4,5	3,6
9008A	8	121	200	70	391	18	38	152x89	605	34,0	No	7,3	5,5
9112A	12	149	241	80	470	26	48	165x106	605	27,2	Yes	10,9	7,9
9015B	15	156	230	114	505	27	60	130x140 †	700	40,8	No	13,6	8,3
9120A	20	159	270	92	521	22	51	183x129	800	31,8	Yes	18,1	12,9
9022B	22	156	240	109	521	36	60	165x160 †	700	40,8	Yes	20,0	10,7
9030A	30	159	279	—	438	35	60	192x141	1000	22,7	Yes	27,2	18,7
9033B	33	143	240	106	502	56	65	184x176 †	700	39,9	Yes	29,9	14,5
9050A	50	171	305	—	476	36	76	237x187	1000	38,6	Yes	45,4	35,4
9110B	110	156	300	—	456	40/160 ‡	111	339x291	700	35,8	Yes	99,8	70,0

† Comes with a Beveled Base.

‡ 2 Speed: Rapid advance≈40 strokes; Lift mode≈160 strokes.

Model Shown:
9006X, 9011X, 9013X



Features

THE RIGHT CHOICE FOR THOSE LOWER HEIGHT APPLICATIONS FOR MRO.

- Telescoping jacks offer all of the quality features and capabilities of the standard bottle jack line with a bonus. The super-long stroke of these jacks saves time and effort by eliminating the need to lift or crib. In most applications, the user can place the jack once and complete the lift.
- The 9006X, 9011X and 9013X all feature a unique beveled base that allows the jack to “follow” the load laterally as it is raised, greatly reducing side-loading of the piston.
- High strength piston and pump linkage for long life.
- All models include over-travel protection.
- Lever Bar included on all models.
- All jacks meet ASME B30.1 standards and carry the Power Team PowerThon™ Lifetime Warranty.

Jacks

Ordering Information

Order Number	Cap. (tons)	Stroke (mm)	Retracted Height (mm)	Length of Screw Ext. (mm)	Height with Screw Ext. (mm)	No. Pump Strokes to Ext. Piston	Saddle Dia. (mm)	Base Size Beveled Base (mm)	Pump Handle Length (mm)	Handle Effort at Rated Cap. (kg)	Carry Handle	Metric Tons @ 700 bar	Prod. Wt. (kg)
9006X	6	305	216	—	512	14	44	121x133	700	36	No	5,4	6,4
9011X	11	262	200	68	530	25	41	160x165	700	40	No	10,0	8,8
9013X	13	254	230	84	570	35	48	176x186	700	36	Yes	11,8	11,3

Model Shown:
J24T, J55T, J106T

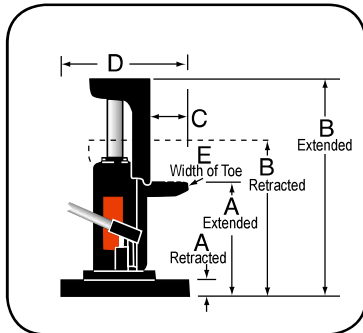

Features

LOW HEIGHT INDUSTRIAL LIFTING AND PUSHING APPLICATIONS.

- These bottle jack-style toe jacks are loaded with many of the same features as our standard bottle jacks, but the toe-lift feature and swiveling pump handle socket make them ideal for machinery lifting and positioning.
- An internal pressure relief provides added safety by limiting the jack's lifting capability to the capacity of the toe.
- Spring return is an added feature on the J55T and J106T jacks.
- Swiveling pump handle assembly available on the 5 and 10 ton models. The swiveling jack assembly allows you to access and pump the unit from numerous positions.
- High strength piston and pump linkage for long life.
- All models include over-travel protection.
- Lever Bar included on all models.
- All jacks meet ASME B30.1 standards and carry the Power Team PowerThon™ Lifetime Warranty.

Technical Dimensions

Order Number	Ret.	Ext.	Ret.	Ext.	C (mm)	D L x W (mm)	E (mm)
	A		B				
	(mm)	(mm)	(mm)	(mm)			
J24T	16,0	139,7	235,0	355,6	47,8	283 x 240	50,8
J55T	25,4	149,4	292,1	416,1	47,8	283 x 240	76,2
J106T	31,8	181,1	327,2	476,3	63,5	283 x 240	100,1

Ordering Information

Order Number	Cap. (tons)	Max. Lift Stroke (mm)	Strokes to Ext. Piston (25 mm)	Handle Effort at Max. Load (kg)	Carry Handle	Metric Tons at 700 bar	Prod. Wt. (kg)
J24T	2	121	14	19	Yes	1,8	8,3
J55T	5	121	22	27	Yes	4,5	24,0
J106T	10	146	31	33	Yes	8,1	38,0

Model Shown:
J259T, J1095, J58T

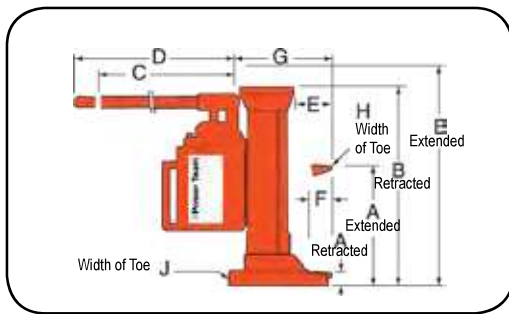

Features

HEAVY-DUTY, LOW HEIGHT INDUSTRIAL LIFTING AND PUSHING APPLICATIONS.

- With lifting points on the toe and on the top, these extremely rugged jacks are ideal for machine lifting, rigging, lift truck service and much more.
- Choose from 5.5 ton, 11 ton, or the 27.5 ton lifting capacity.
- All jacks operate both vertically and horizontally.
- Base, toe and pumping assembly swivel independently, allowing the jack to work in confined areas.
- High strength piston and pump linkage for long life.
- Lever Bar included on all models.
- All jacks meet ASME B30.1 standards and carry the Power Team PowerThon™ Lifetime Warranty.

▶ **J58T hydraulic toe jack is the perfect choice for the pallet jack application.**



Technical Dimensions

Order Number	Ret.	Ext.	Ret.	Ext.	C	D	E	F	G	H	J
	A		B								
	(mm)	(mm)	(mm)	(mm)							
J58T	30	238	375	584	368	451	71	56	176	41	130
J109T	30	264	419	654	368	451	76	56	183	64	171
J259T	54	289	505	738	210	756	146	102	267	89	270

Ordering Information

Order Number	Cap. (tons)	Max. Lift Stroke (mm)	Strokes to Ext. Piston (25 mm)	Handle Effort at Max. Load (kg)	Carry Handle	Metric Tons at 700 bar	Prod. Wt. (kg)
J58T	5,5	210	8	38	Yes	5,0	19,5
J109T	11,0	235	13	40	Yes	10,0	29,0
J259T	27,5	235	21	40	Yes	24,9	92,1